



VALVULA DE COMPUERTA

GATE VALVE

NORMAS ANSI

**Fig. VS
132**

**SERIE
150 Lbs**

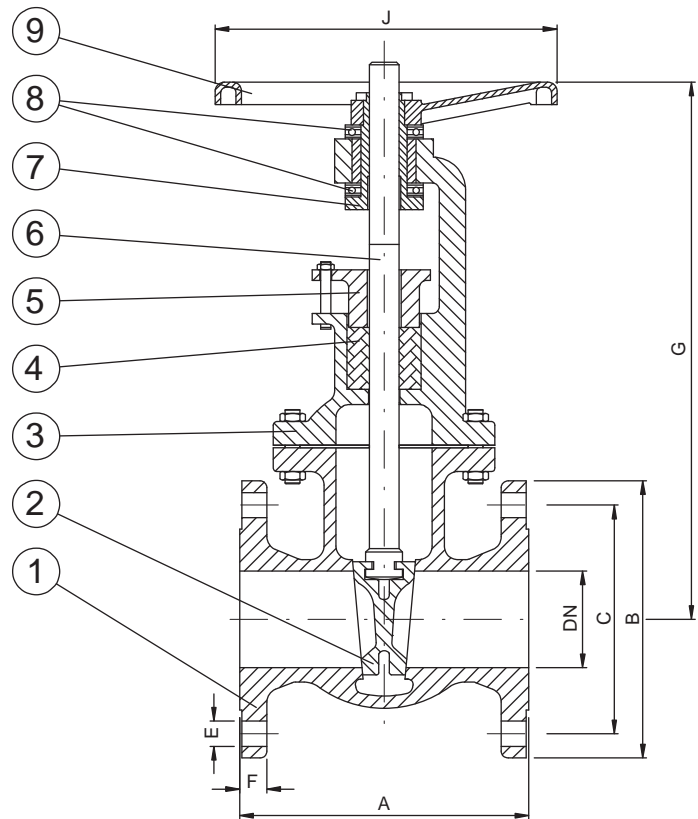

VALVULA DE COMPUERTA. ASA 150

- Paso recto.
- Tapa puente atornillada
- Husillo exterior ascendente.
- Volante fijo.
- Cuña de doble disco o sólida.
- Bridas dimensionadas y barrenadas s/n ASA B-16.5.
- Distancia entre caras s/n ASA B-16.10.
- Pasos de 2" a 10".

GATE VALVE. ASA 150

- *Direct access.*
- *Bolted yoke bonnet.*
- *Outside rising stem.*
- *Non rising handwheel.*
- *Wedge of double disk or solid.*
- *Drilled and dimensioned flanged according ASA B-16.5.*
- *Distance between sides, according ASA B-16.10.*
- *Sizes from 2" to 10".*

CUADRO DE DIMENSIONES NORMAS DIN
DIMENSIONS PANEL

PASO/SIZE	A	B	C	F	G	JØ	Nº Agujeros Nº of Holes	E
2"	178	152	120,6	16	320	200	4	20
2 1/2"	190,5	178	139,7	17,5	335	250	4	20
3"	203	190	152	19	350	250	4	20
4"	228,6	229	191	24	475	320	8	20
6"	266,7	280	241	25,4	650	360	8	23
8"	292	343	298	29	770	425	8	23
10"	330	406	362	30,5	910	500	12	26