



VALVULA DE RETENCION A PISTON INCLINADA

LIFT CHECK VALVE "Y-PATTERN"

NORMAS DIN

Fig. VS
122

SERIE
PN-16/40

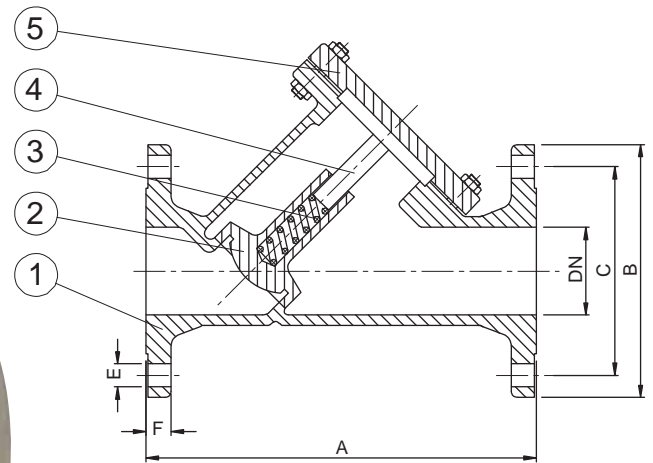

PARA MONTAJE HORIZONTAL O VERTICAL
TO HORIZONTAL OR VERTICAL ASSEMBLING

Nº	DENOMINACIÓN / PART	MATERIAL
1	CUERPO / BODY	INOX CF8M
2	CIERRE / DISC	INOX CF8M
3	MUELLE / SPRING	INOX 316
4	GUÍA / GUIDE	INOX 316
5	TAPA / COVER	INOX CF8M

Otros materiales / dimensiones consultar
Others materials / dimensions on request

VALVULA DE RENTENCION A PISTON INCLINADA

- Se puede colocar en posición horizontal o vertical.
- Mediante resorte se consigue cierre más rápido y estanco.
- Bridas dimensionadas y barrenadas s/n DIN series PN-16 o PN-40.
- Distancia entre caras s/n DIN 3202 F-1.
- Pasos de 15 a 300 mm. PN-16
15 a 150 mm. PN-40

LIFT CHECK VALVE "Y-PATTERN"

- It can be used horizontally or vertically.
- With the help of a spring, loaded a more watertight and quicker sealing can be obtained.
- Drilled and dimensioned flanged according to DIN PN-16 or PN-40.
- Distance between sides according to DIN 3202 F-1.
- Sizes from 15 to 300 mm. PN-16
15 to 150 mm. PN-40

CUADRO DE DIMENSIONES NORMAS DIN

DIMENSIONS PANEL

DN	15	20	25	32	40	50	65	80	100	125	150	200	250	300
A	130	150	160	180	200	230	290	310	350	400	480	600	730	850
B	95	105	115	140	150	165	185	200	220	250	285	340	405	445
C	65	75	85	100	110	125	145	160	180	210	240	295	350	400
F	14	16	16	16	18	18	18	20	20	22	22	24	26	26
E	14	14	14	18	18	18	18	18	18	18	23	23	23	23
N*	4	4	4	4	4	4	4	8	8	8	8	8/12	8/12	12
Peso (kg) Weight (kg)	4	5	6	8	10	14	17	22	32	51	83	132	205	272

* N° de agujeros / N° of holes